

Product Data Sheet: VOCALARM™ Voice Enhanced Sounder

Description

Each VOCALARM™ is synchronised by the use of a high crystal oscillator.

Clarity is maintained via the use of a high quality digitised voice messaging system that makes use of a low current drive circuit. For two stage alarms, a continuous tone is added to the VCL01.

With a growing choice of messages for a wide variety of applications including fire, security and factory automation, the VOCALARM™ gives increased flexibility for those requiring the very best human response in an emergency situation.

Note that each message is preceded by a 6 second sweep tone as standard, in line with BS 5839.



Message List

No.	Description
Messages available for VCL-01* are:	
01A	Attention! Attention! Please leave by the nearest exit.
02B	In the interest of safety please evacuate the building immediately.
03C	Fire! Please leave the building. Fire! Leave the building.
04D	Fire Emergency! Please remain calm and evacuate the building immediately.
05E	A fire has been detected, please leave the building by the nearest exit.
06F	A fire detector has operated. Please leave the building via the nearest exit.
07G	We have an emergency. Please leave the building via the nearest exit.
08H	Fire emergency! Please leave the building.
09J	In the interest of fire safety, please leave the building by the nearest exit.
10K	This is a fire alarm. Please leave the building via the nearest exit.
11L	This is a fire warning. Please evacuate the building.
12M	Emergency! Please leave the building by the nearest exit.
13N	This is a security alert. Please leave the building by the nearest exit.
14P	There has been a security breach. Please leave the building as directed by staff.
15Q	This is a secure area. Do not enter at the present time.
16R	This is a general evacuation alert. Please leave the building.
17S	Staff Alert Code 100. Staff Alert Code 100.
18T	Staff Alert Code 101. Staff Alert Code 101.
19U	Staff Alert Code 102. Staff Alert Code 102.
20V	This is a security alert. Please leave the building as directed by staff.
21W	Warning! Stand clear of all machinery. Warning! Stand clear of all machinery.
22X	This is a start up warning. Please stand clear of all machinery.
23Y	This is a no-smoking vehicle. Please extinguish your cigarette.
24Z	This is a no-smoking area. Please extinguish your cigarette. A member of staff has been contacted.
25AA	Warning! Pump starting. Warning! Pump starting.
26AB	Warning! High moisture level detected. Warning! High moisture level detected.
27AC	Warning! High level reached. Warning! High level reached.
28AD	Warning! Weight limit reached. Warning! Weight limit reached.
29AE	Attention! Attention! In the interest of safety please evacuate the building immediately
30AF	Ladies & Gentlemen, due to unforeseen circumstance we must ask you to leave the building immediately by the nearest exit or as directed by a member of staff.
32AH	Attention! Attention! Please leave via the rear stairs.
33AJ	Attention! Attention! Please do not use the stairs.
34AJ	Attention! Attention! Please leave by the nearest exit.
35AK	In the interest of safety please leave the building immediately by the nearest exit or as directed by a member of staff.
36AL	Warning! Gas release imminent. Please leave the building.
EF1	Move away from the exit doors and glass façade.
VIRGIN 3	Warning high temperature has been detected in the computer room.
Messages available for VCL-02* are: 10K & 12M, 23Y & 24Z, 32AH & 33AJ and 32AH & 34AJ.	

Technical Information

Part No.	VCL-01*	VCL-02**
Supply Voltage Range:	15 - 30Vdc	
Tone @ 1 metre 24Vdc:	100dBa	
Message Output @ 1 metre 24Vdc:	c. 97dBa	
Current @ 24Vdc:	c. 29mA	
Operating Tone Frequency:	800Hz to 1000Hz	
Number of Messages:	1	2
Volume Control:	- 25dBa	
IP Rating:	IP65	
Temperature Range:	- 20°C to + 70°C	
Weight (per unit packed):	215g	

Sounders are available in red or white by adding - R, red or W, white to the end of the part number.

Dimensions

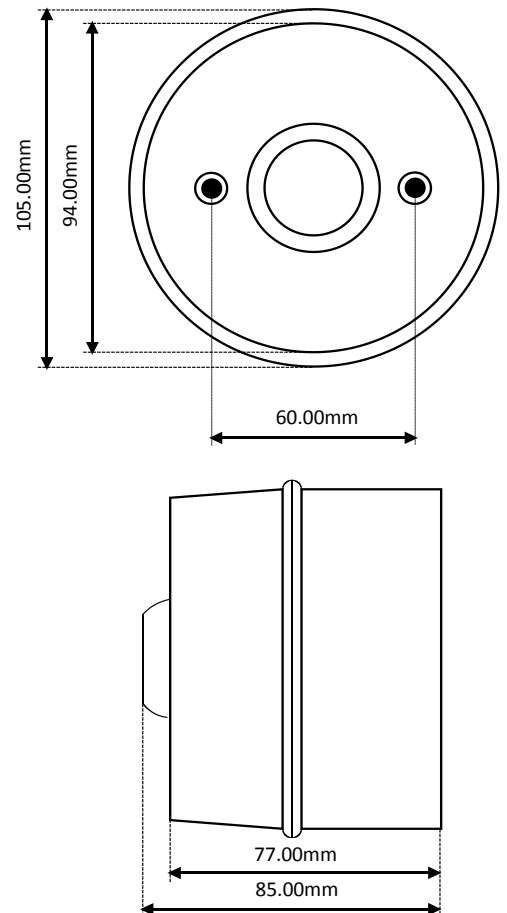

Connection

