

Product Data Sheet: FDG Series Wireless/Acoustic Door Retainers



Description

The FDG series provides a wire-free solution for holding open fire doors in any position.

The units are easy to install and improve access for wheelchair users in line with the Disability Discrimination Act. Available in a variety of colours and also featuring an automatic night-time release facility.

The FDG is suitable for normal environments such as offices, care homes and hotels. The Dorgard X incorporates the very latest radio technology making it suitable for very noisy environments such as bars, restaurants and public areas that have an automatic fire detection system installed.

BS EN 1155: 1997 building hardware. Electrically powered hold-open devices for swing doors. (Manufacturers classification number 357113). BS EN 50081-1: 1992 electro-magnetic compatibility. Generic emission standard. Residential, commercial and light industry. BS EN 50082-1: 1997 electro-magnetic compatibility. Generic immunity standard. Residential, commercial and light industry.

In addition to the variety of colours both systems can be supplied in, we have metal covers available in both polished brass and brushed steel.

Technical Information

Part No.	FDG-ACOUSTIC	FDG-X
Casing Colour	Black, Red, White or Mahogany	
Casing Material:	ABS	
Power, alkaline batteries:	2 x 1.5V C size	4 x 1.5V C size
Expected Battery Life:	12 Months	
Trigger:	2.4KHz continuous above 65dBa	NA
Weight:	950g	670g



Dimensions

FDG-X-REC / FDG-ACOUSTIC

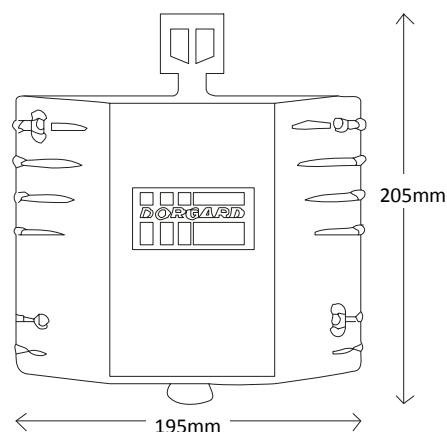

FDG-X-TRANS

