

## Product Data Sheet: IP65 Series Wall Mounted Door Retainers



- **ROBUST STEEL CONSTRUCTION**
- **1200N HOLDING FORCE**
- **SEALED AGAINST WATER INGRESS**
- **24Vdc & 230Vac MODELS AVAILABLE**
- **SUPPLIED WITH KEEPER PLATE**

### Description

The IP65 door holder is designed to hold open fire doors for convenient access through busy door ways and release them for closing when an alarm is triggered. It is designed for wall mounting and is supplied complete with keeper plate for fixing to the fire door. Both parts are constructed from steel and are zinc plated.

The strong construction makes this magnet ideal for most applications in all types of building. The high level of ingress protection also means that this magnet is particularly suited to use outdoors and in maritime applications.

Electrical connection is via an IP65 connector supplied with the magnet.

### Technical Information

Technical Information	IP65-24V	IP65-230V
Voltage Supply:	24Vdc	230Vac
Current Consumption:	300mA	45mA
Holding Force:	1200N	
Residual Force:	20N max	
Ingress Protection:	IP65	
Ambient Temperature:	0 - 50°C	
Weight:	2.0Kg	

### Dimensions

#### Keeper Assembly

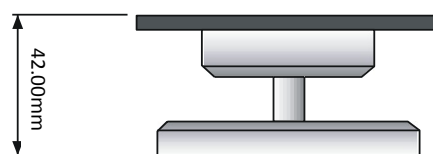
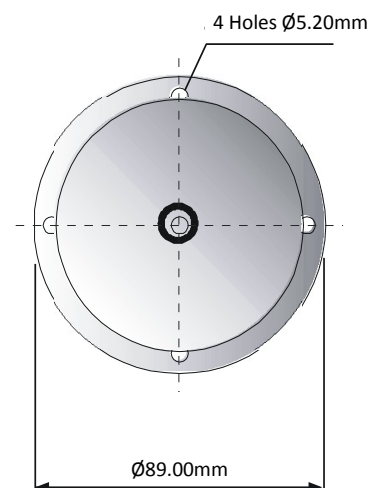

#### Electromagnetic Assembly

