

## Product Data Sheet: DRW Series Wall Mounted Door Retainers



### Description

The DRW door retainers are exclusive to Cranford Controls, they combine good looks, high performance and economy in one new low profile package.

With a flame retardant, low profile ABS plastic body or a robust steel facia plate, curvy shape closely matches the curves of the VTG sounder, making a continuous look possible when installing other Cranford Controls products in high profile applications.

Installation is, with knockouts provided for entry of surface mount conduit, there is ample sound to connect external wiring to the 4.0mm terminals.

Each DRW door retainer is fitted with a spring loaded release pin mounted centrally within the electro-magnet. On power off, the release pin then ensures that the fire door is pushed away from the electro-magnet.

Additional accessory products are available, including floor brackets, chains and additional keeper plates.

All Cranford Controls door retainers are designed to comply to the latest requirements of EN 61000-3-2, EN 50081-1, EN 60950 and EN 1155.

### Technical Information

Part No.	DRW-L500	DRW-L-M	DRW-L	DRW-M	DRW-M-M
Supply Voltage and Tolerance:	24Vdc $\pm$ 10%			230Vac $\pm$ 10%	
Current Consumption:	50mA			12mA	
Rated Holding Force:	450N (20.4kg)	200N (20.4kg)			
Maximum Holding Force:	750N (25.5kg)	250N (25.5kg)			
Residual Holding:	ZERO				
Release Switch:	YES				
Protection:	IP51				
Keeper Adjustment:	$\pm$ 30 °				
Weight (per unit packed):	500g	420g	400g	400g	420g
Material:	ABS	Steel	ABS	ABS	Steel
Door Closer, Power Size:	3 - 6				

### Dimensions

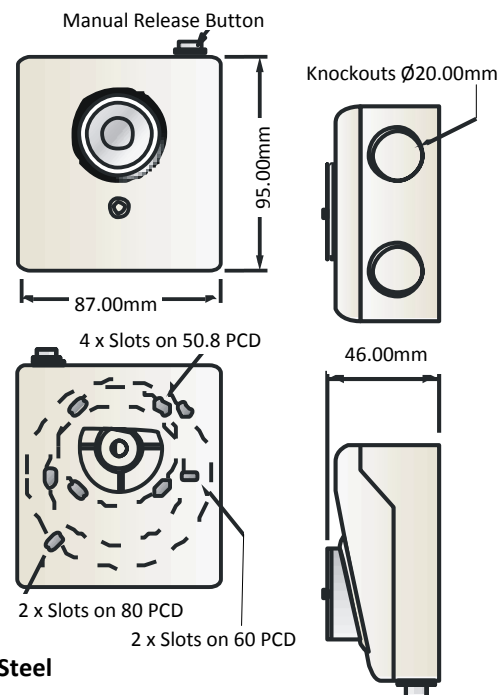

### Steel

