

Product Data Sheet: 300 Series Power Supply Units

Description

The 300 series range of Power Supply Units will provide 27.6Vdc at the nominated current.

Batteries are monitored continuously to ensure and communicate an adequate state of charge. A fault condition is given via the volt free contacts.

Note that batteries with a supply voltage greater than 18V are needed to activate the charging circuit. The units are factory adjusted to provide a 27.6Vdc output. When fitted, a lead acid rechargeable battery can be charged and then trickle charged to maintain optimum condition.

The mains present indicator is a green LED and the amber LED pulses in fault conditions. During mains failure the load will be supplied from the rechargeable battery; the battery must be connected correctly to prevent damage. An automatic disconnect circuit will operate if the battery voltage becomes too low.

Volt free relay contacts are available at the terminal block. The relay changes state to indicate any of the following faults; mains failure, output fuse failure or load short circuit, battery low, missing or short-circuit.

The 300 series power supply is supplied within a sturdy metal enclosure with a hinged lid and have been designed for rapid installation.



Dimensions

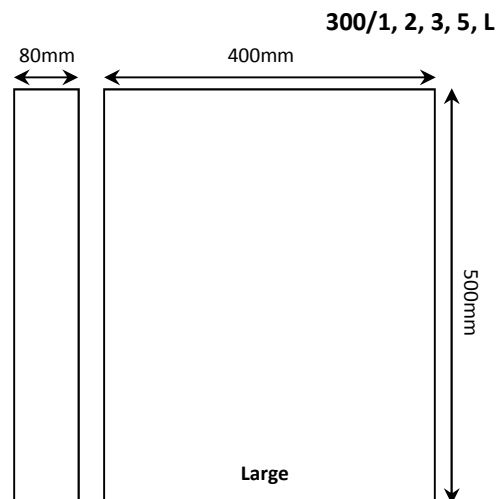

300/1, 2, 3, 5

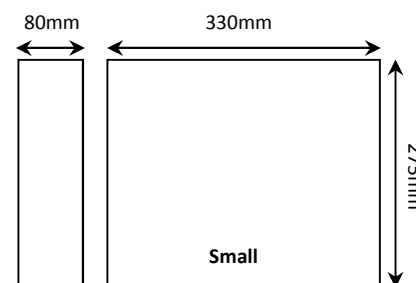

Technical Information

Part No.	300/1	300/2	300/3	300/5
Supply Voltage:	230V + 10% - 15% 50Hz			
Load Output @ 27.6Vdc:	0.5A	1.5A	2.5A	4.5A
Load Voltage Regulation:	0.9%			
Max Output Ripple:	50mV			
Maximum Battery Size:	2x 7Ah 12V	2x 7Ah 12V	2x 7Ah 12V	2x 7Ah 12V
Battery Recharge Time:	80% Capacity - 24 hours			
Temp Range:	- 10°C to 40°C			
Relative Humidity:	Up to 95% Relative Humidity			
Output Fuse Rating:	F1.25A	F2.00A	F3.75A	F5.00A
Weight:	3.99kg	4.66kg	5.56kg	5.58kg
Batteries Not Supplied				

Connection

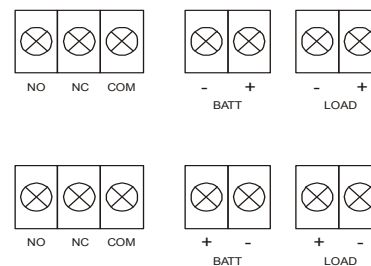

NOTE: THIS PRODUCT MUST BE EARTHED.

Connect load to LOAD terminals.

Connect sealed lead acid batteries to BATT terminals observing correct polarity.

This unit must be used with dc appliances only.